



# J12

3U Active Air Cooler

**PRODUCT SPECIFICATIONS**

Specification Version: 06/16/2023

*(Specifications are subject to change without notice)*

## Model Number: J12

- Recommend for AMD® CPU as following
  - AMD® Genoa® Processor Family, Socket SP5
- Active Air Cooler for 3U Server and Up

## Overall Specification

Dimension	118.0 x 92.4 x 105.0 mm
Weight	798g
Material	Aluminum Fin + Heat pipes + Copper Heat Spreader Embedded Aluminum Heatsink Base
Thermal Grease	Shin-Etsu 7762 or Equivalent
TDP	Up to 320 Watts at 30°C ambient temperature

## Cooling Fan Specification

Model Number	DF128038BX-E
Dimension	80 x 80 x 38 mm
Bearing	Double Ball
Rated Voltage	DC 12V
Rated Speed	At Duty Cycle 0~20%: 2400± 200 RPM At Duty Cycle 50%: 4800± 10% RPM At Duty Cycle 100%: 8000±10% RPM
Input Power	At Duty Cycle 0~20%: 1.2 W At Duty Cycle 50%: 5.52 W At Duty Cycle 100%: 24.72 W
Maximum Airflow	At Duty Cycle 0~20%: 32.52 CFM At Duty Cycle 50%: 67.24 CFM At Duty Cycle 100%: 115.61 CFM
Rated Static Pressure	At Duty Cycle 0~20%: 3.45 mm-H2O At Duty Cycle 50%: 13.6 mm-H2O At Duty Cycle 100%: 38.3 mm-H2O
Acoustical Noise	At Duty Cycle 0~20%: 25.63 dBA At Duty Cycle 50%: 47.85 dBA At Duty Cycle 100%: 64.40 dBA
Lead Wire Pin Out	Pin#1- Black(-) Pin#2- Yellow(+) Pin#3- Green(Tachometer/ Signal Output) Pin#4- Blue (PWM)

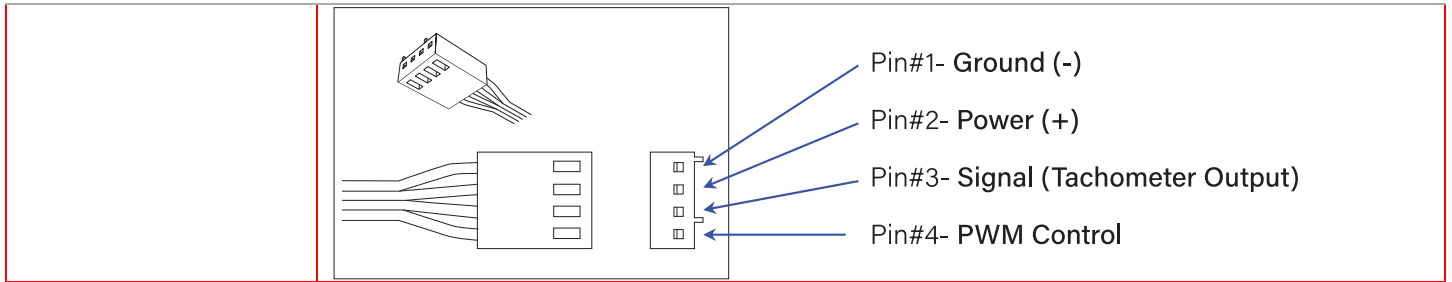
**J12 | Socket SP5**

### Performance Chart: Active Cooler J12 Thermal Resistance Thermal Resistance vs. Fan Speed (Duty Cycle and RPM)

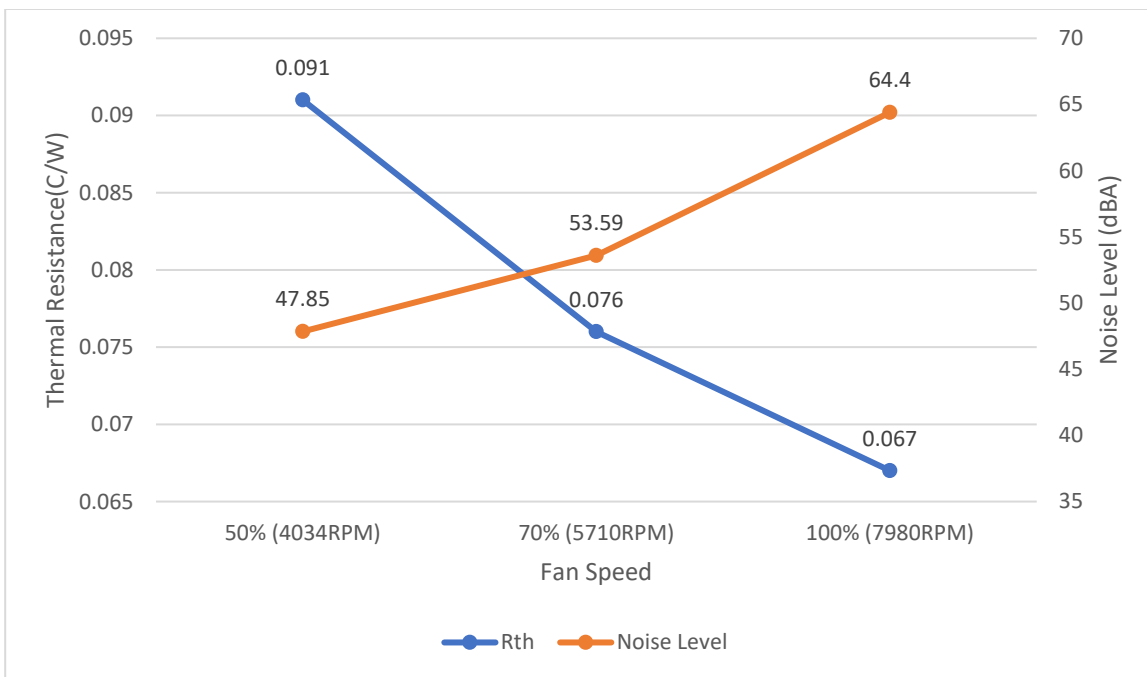

**CONFIDENTIAL DOCUMENT**

THIS DRAWING CONTAINS INFORMATION PROPRIETARY TO DYNATRON CORPORATION AND DYNAEON INDUSTRIAL CO., LTD. ANY REPRODUCTION, DISCLOSURE, OR USE OF THIS DRAWING IS EXPRESSLY PROHIBITED EXCEPT AS DYNATRON CORPORATION AND DYNAEON INDUSTRIAL CO., LTD. MAY OTHERWISE AGREE TO IN WRITING.

REV#	DESCRIPTION	CHECKER	DATE
0.0	INITIAL RELEASE	Engr.	03/11/22
0.1	FAN SPEC. UPDATE	Engr.	04/28/22

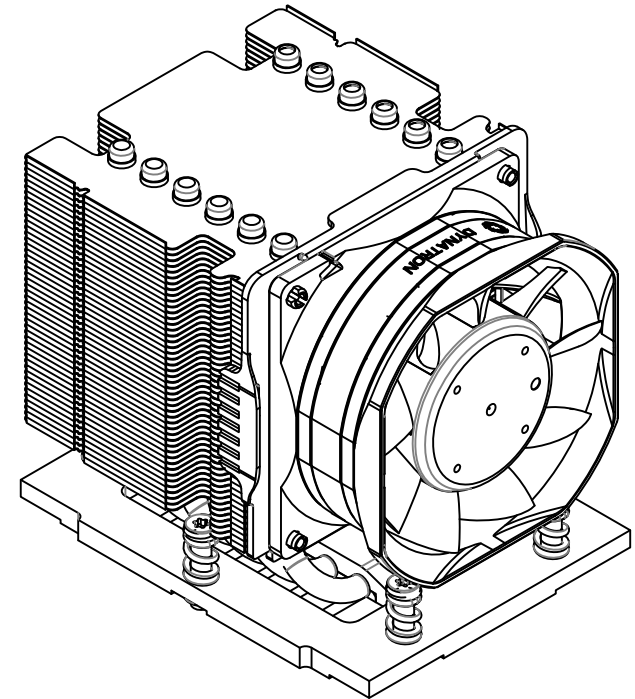
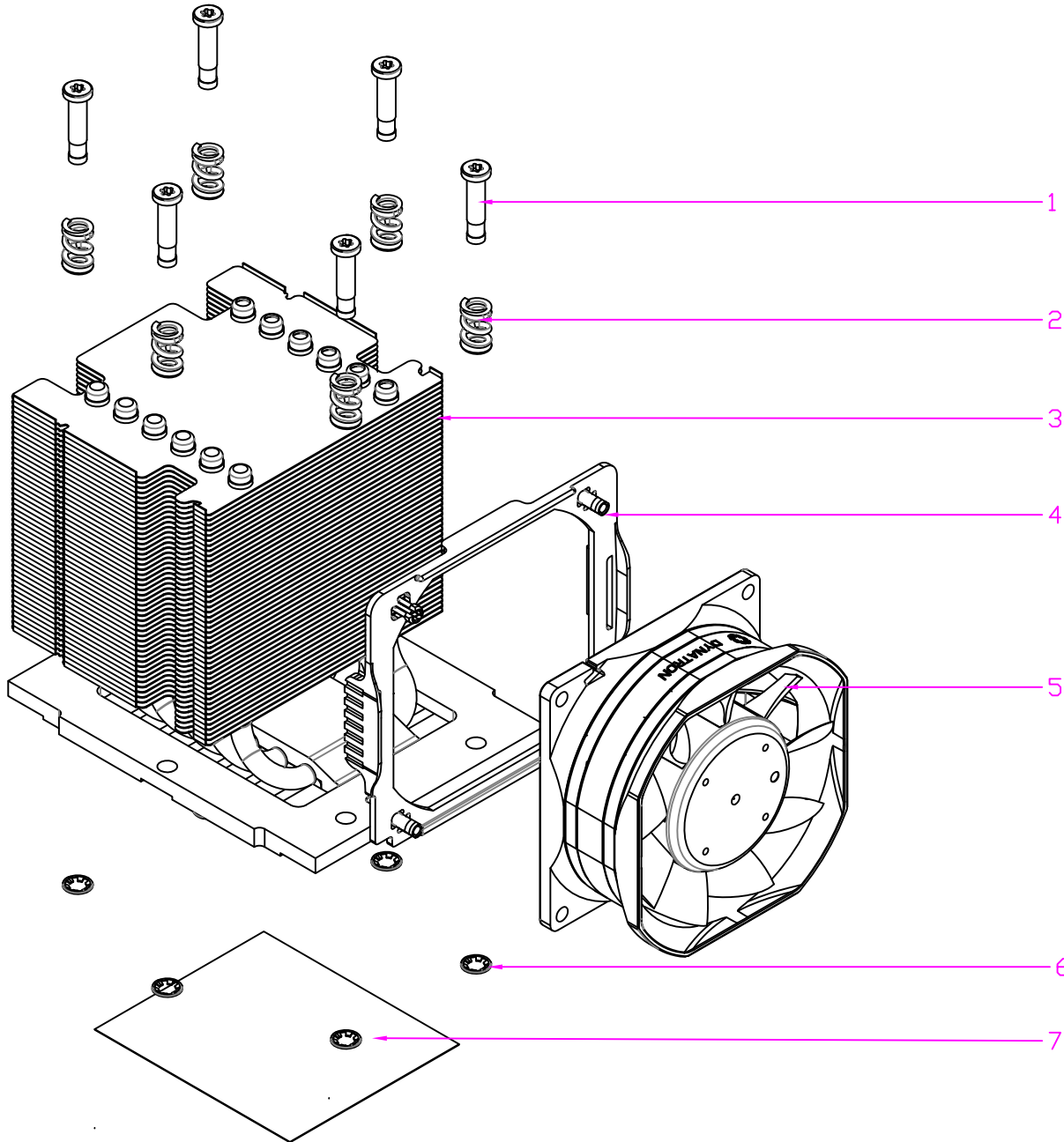

7	THERMAL GREASE	SHIN-ETSU 7762	N/A
6	C-RING	STEEL	6
5	FAN	DF128038BX-E	1
4	FAN RETENTION BRACKET	PLASTIC	1
3	HEATSINK	ALUMINUM FINS + HEAT PIPES + COPPER HEAT SPREADER EMBEDDED ALUMINUM BASE	1
2	SPRING	STEEL	6
1	SCREW, HEATSINK	STEEL	6
ITEM #	DESCRIPTION	MATERIAL	QTY.

DATE	NAME	 DYNATRON CORPORATION		
04/28/22	Engr.			
CHECKED	04/28/22	Engr.	TITLE: 3U Air Cooler J12 BOM & Exploded Assembly Drawing	
ENG. APPR.				
MFG. APPR.				
QA				
COMMENTS			DWG. No: DYN-EP-J12	REV 0.1

**NOTES:**

1. THE FIGURE IS FOR REFERENCE ONLY, AND NOT FOR SCALE

REV#	DESCRIPTION	CHECKER	DATE
00	INITIAL RELEASE	Engr.	02/12/22
01	FAN SPEC. UPDATE	Engr.	04/28/22

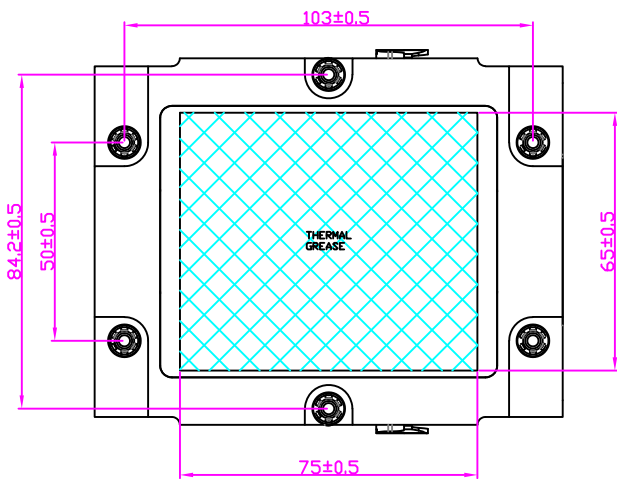
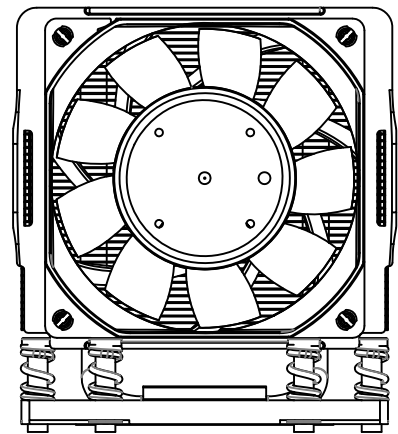
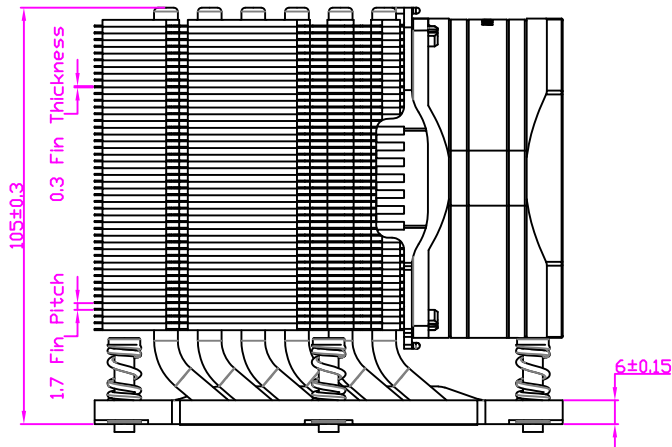
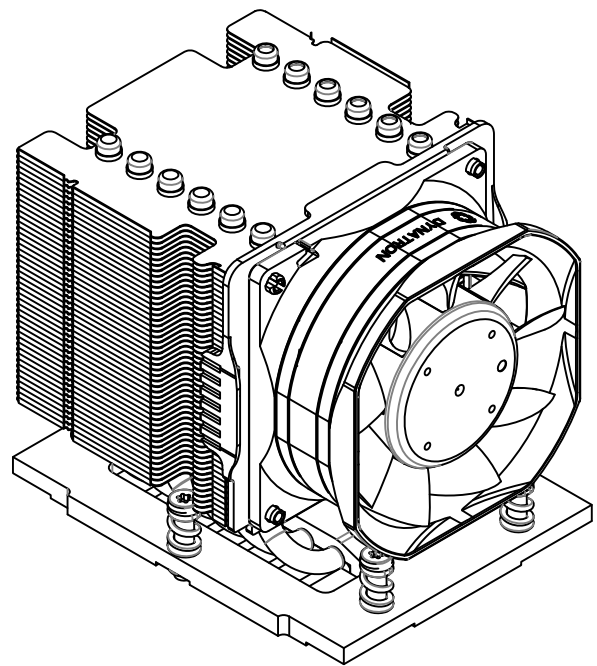
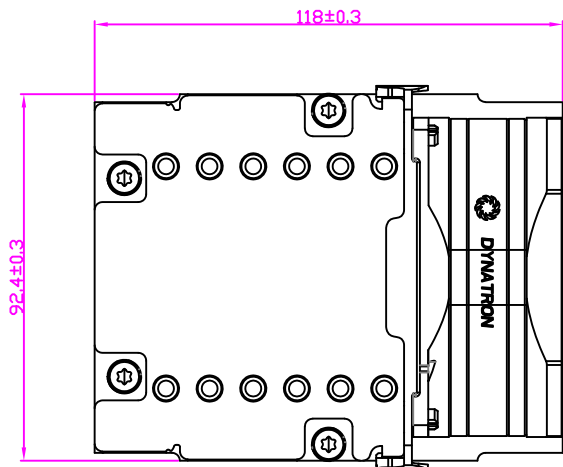

	NAME	DATE
DRAWN BY	ENGR	04/28/2022
CHECKED BY	ENGR	04/28/2022
ENG. APPROVED		
MFG. APPROVED	-	-

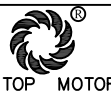

**DYNATRON CORPORATION**

TITLE: 3U Air Cooler J12  
Overall Dimension Drawing

**CONFIDENTIAL DOCUMENT**  
THIS DRAWING CONTAINS INFORMATION PROPRIETARY TO DYNATRON CORPORATION AND DYNAEON INDUSTRIAL CO., LTD. ANY REPRODUCTION, DISCLOSURE, OR USE OF THIS DRAWING IS EXPRESSLY PROHIBITED EXCEPT AS DYNATRON CORPORATION AND DYNAEON INDUSTRIAL CO., LTD. MAY OTHERWISE AGREE TO IN WRITING.

VIEW		DWG. No:	REV.
UNITS	MM	DYN-BD-J12	0.1

## Publication History:

06/16/2023: Maximum Supported TDP update

08/01/2022: Thermal Performance Chart Update

07/25/2022: Thermal Performance Chart Update

04/28/2022: Fan Spec. Update

03/11/2022: Initial Release

*(Specifications are subject to change without notice)*